

ASSEMBLY INSTRUCTIONS

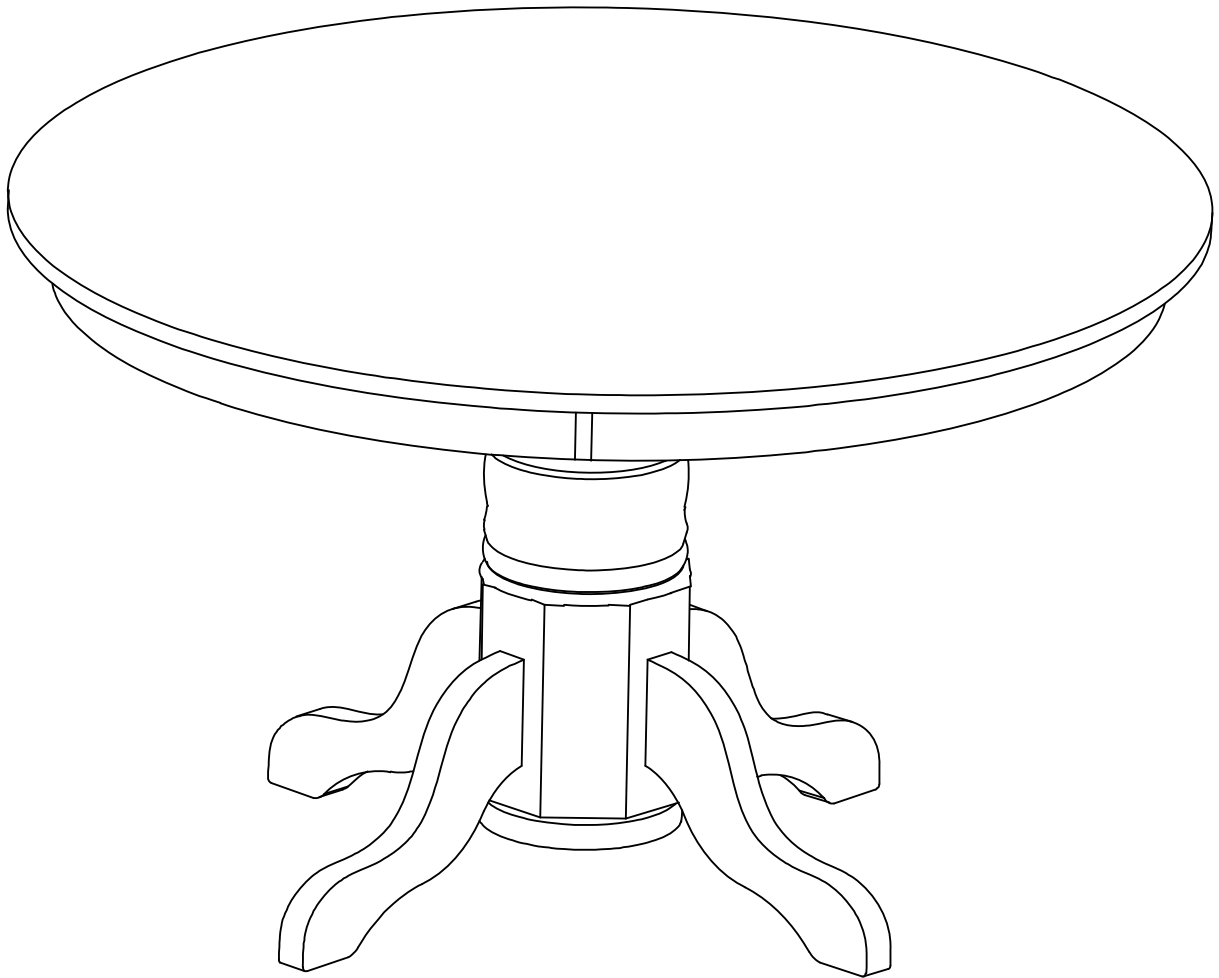

Description : TURNED DINING PEDESTAL SOLID TOP
Item No. : T-48B AND T-48RT OR T-52T
(PACKED IN SEPARATE BOX)

ITEM NO : T-48B AND T-48RT OR T-52T
(PACKED IN SEPARATE BOX)
REVISED NOV 27, 2014

Printed in Vietnam

BEFORE ASSEMBLY

Thank you for purchasing this quality product. This product has been designed for easy assembly and constructed for durability. All parts were checked prior to packaging to insure quality. Prior to beginning assembly, however, make sure all parts and hardware are included and free of obvious defect. If a part is missing or defective, please contact the store where purchased. If hardware is missing, or you need help with assembly, please call toll free 888-944-8396.

IMPORTANT NOTE:

- Place all wooden parts on a clean and smooth surface such as a rug or carpet to avoid the parts from being scratched.
- Remove all wrapping material, including staples & packing straps before you start to assemble.
- DO NOT tighten all screws and bolts until completely assembled.
- Keep all hardware parts out of reach of children.

WARNING:

Long exposure to rubber or soft plastic may cause a chemical reaction and damage the finish of your table. Protect the surface of the table with cloth if you are using any product with rubber feet or base.

PART LIST T-48RT OR T-52T

When unpacking, please be careful not to discard any parts with the packaging. Before continuing, please make sure you have the following parts:

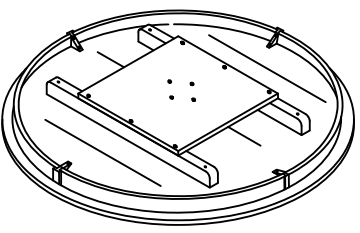
NO	Description	Qty	Sketch	NO	Description	Qty	Sketch
A	Top	1					

PART LIST T-48B

When unpacking, please be careful not to discard any parts with the packaging. Before continuing, please make sure you have the following parts:

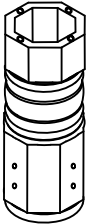





NO	Description	Qty	Sketch	NO	Description	Qty	Sketch
B	Leg	4		C	Pedestal column	1	

ITEM NO : T-48B AND T-48RT OR T-52T
 (PACKED IN SEPARATE BOX)
REVISED NOV 27, 2014

Printed in Vietnam

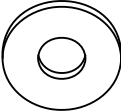
HARDWARE LIST

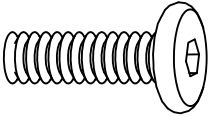
When unpacking, please be careful not to discard any parts with the packaging. Before continuing, please make sure you have all of the following hardware:

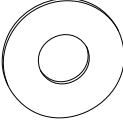
NO	Description	Qty	Sketch	NO	Description	Qty	Sketch
1	Hexagon nut (M8x13mm)	8		2	Lock washer ($\Phi 8.5 \times \Phi 13 \text{mm}$)	12	
3	Flat washer ($\Phi 8.5 \times \Phi 19 \text{mm}$)	8		4	Wrench (13mm)	1	
5	Bolt (M8x45mm)	4		6	Allen Key (4x80mm)	1	
7	Large flat washer ($\Phi 8.5 \times \Phi 22 \text{mm}$)	4					

NOTE : HARD WARE IS PACKED IN CARTON T-48B

STEP 1

Attach legs (B) to the pedestal (C) with washers (2), (3) and nuts (1) as shown below. Tighten with the wrench (4).

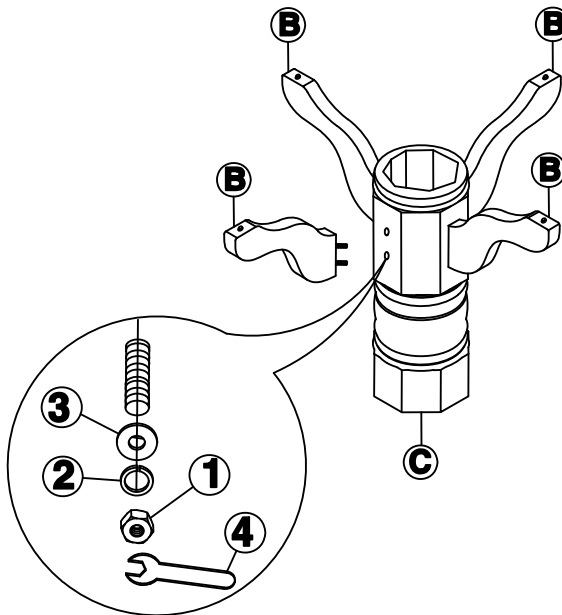

ITEM NO : T-48B AND T-48RT OR T-52T
 (PACKED IN SEPARATE BOX)
REVISED NOV 27, 2014

Printed in Vietnam

STEP 2

Use the Allen key (6) to loosen the bolts and washers, and take off the plate underneath the table top.

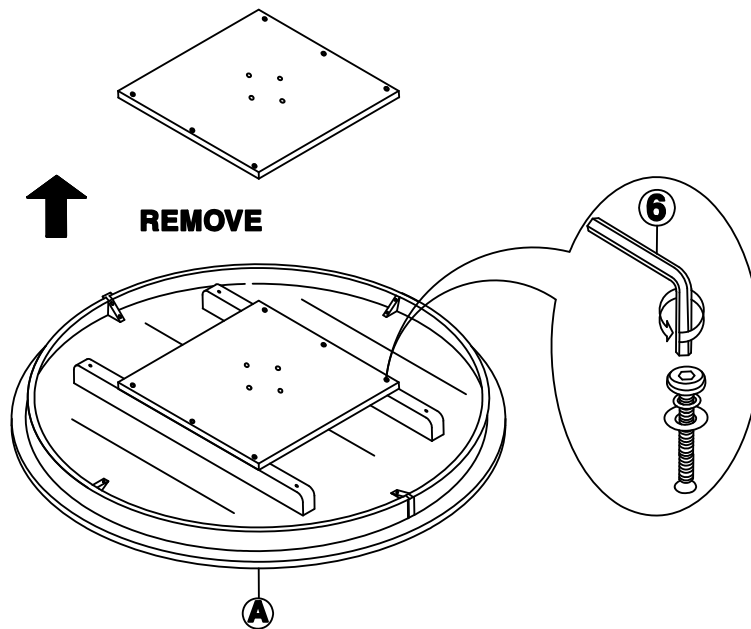

STEP 3

Place the plate on top of the pedestal (C), attach with bolts (5), and washers (2) and (7) as shown below. Tighten with the Allen key (6).

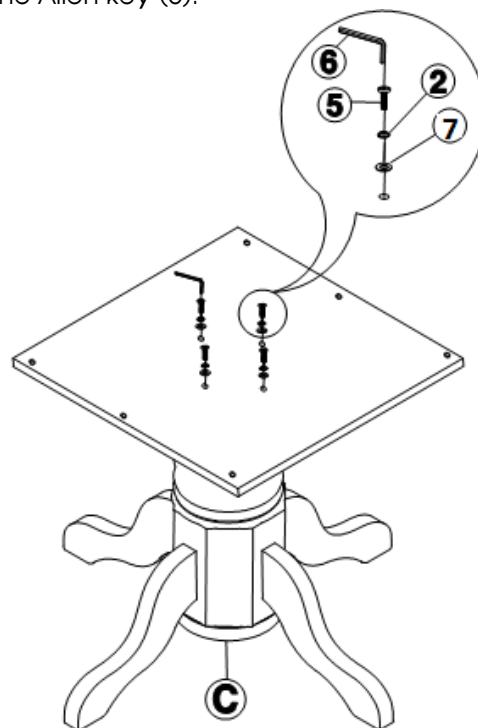

STEP 4

Carefully put the pedestal block on the bottom side of the table top, attach the top to plate with bolts and washers (from step 2) and tighten with the Allen key (6).

